

Subject	Page
Expansion Tank and Brake Fluid Level Switch. . . . .	30
Brake Pressure Sensors. . . . .	31
Wheel Speed Sensors. . . . .	32
Rotation Rate Sensor. . . . .	35
Steering Angle Sensor. . . . .	36
Transverse Acceleration Sensor. . . . .	37
DSC Button. . . . .	38
Instrument Cluster Warning Indicators. . . . .	39
Principle of Operation. . . . .	40
ABS. . . . .	40
ASC. . . . .	44
DSC. . . . .	48
Workshop Hints. . . . .	55
<b>Bosch DSC III 5.7. . . . .</b>	<b>57</b>
Purpose of the System. . . . .	58
I.P.O. . . . .	59
System Components. . . . .	60
Control unit/Hydraulic unit . . . . .	61
CAN Interface. . . . .	62
Tandem Master Brake Cylinder. . . . .	63
Expansion Tank and Brake Fluid Level Switch. . . . .	63
Pre-charge Pump. . . . .	64
Brake Pressure Sensor. . . . .	64
Brake Light Switch. . . . .	65
Wheel Speed Sensors. . . . .	65
Integrated Rotation and Transverse Acceleration Sensor. . . . .	67
Steering Angle Sensor. . . . .	68
DSC Button. . . . .	69
Instrument Cluster Warning Indicators. . . . .	69
Principle of Operation. . . . .	70
ABS. . . . .	70
ASC. . . . .	74
DSC. . . . .	77
Workshop Hints. . . . .	83
<b>Traction and Stability Control Systems Application Chart. . . . .</b>	<b>85</b>
<b>Review Questions. . . . .</b>	<b>86</b>

---

## **BOSCH DSC III 5.7**

**Model: E46/16**

**Production Date: 330xi 6/00, 325xi 9/00**

### **Objectives**

After completing this module you should be able to:

- Identify functions of the DSC 5.7 that are specific to All-Wheel Drive.
- Identify the components used in the system.
- Understand the operating principles of ABS, ASC and DSC.

---

## Purpose of the System

The Bosch DSC III 5.7 is used in the E46/16 in place of the DSC III MK 60 used on 2wd vehicles. The DSC system is the same as used in the E53. HDC is not a feature on 2001 Xi models.

### Functions that are specific for the All-Wheel Drive system are:

- Modified ABS function.
- ASC+T (All-Wheel Drive version).
- Four wheel ADB function.

### The Bosch DSC III 5.7 system is designed to maintain the vehicle's stability during:

- ABS braking regulation
- ASC+T traction control
- DSC for oversteer and understeer control

Additional features are also programmed into the control module to enhance driver safety and comfort. These features are:

- **CBC** Corner Brake Control
- **EBV** Electronic Brake Proportioning
- **MSR** Engine Drag Torque Reduction
- **DBS** Dynamic Brake System

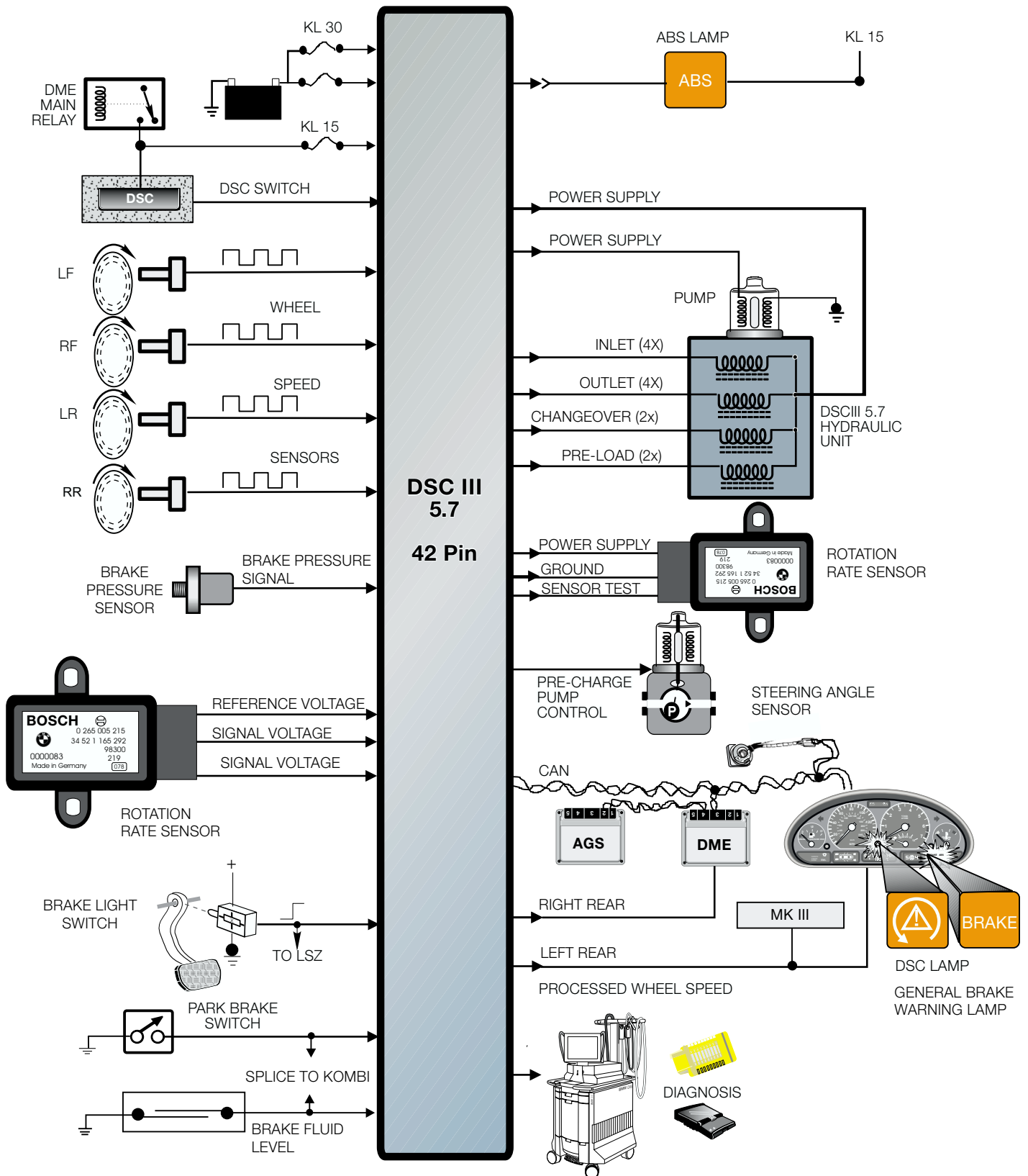

---

## System Components

The Bosch DSC III 5.7 for the E46/16 consists of the following components:

- Integrated Control Unit/Hydraulic Unit with CAN Interface
- Tandem Brake Master Cylinder
- Brake Fluid Expansion Tank with Integrated Level Sensor
- Pre-Charge Pump
- Brake Pressure Sensor (Located on Hydraulic Unit)
- Brake Light Switch
- 4 Wheel Speed Sensors (Active)
- Rotation Rate/Transverse Acceleration Integrated Sensor
- Steering Angle Sensor
- DSC Button
- Instrument Cluster Warning Indicators
- Handbrake Switch
- Wiring Harness

## Control Unit/Hydraulic Unit

The Bosch DSC III 5.7 control unit/hydraulic unit is located inside the engine compartment on the right hand side.

Both the control unit and the hydraulic unit are replaceable as separate components.

All processing functions for ABS, ASC and DSC are performed in the combined control/hydraulic unit. The control unit is also responsible for processing the wheel speed signals and providing them to other control units.



## Bosch DSC III 5.7 Hydraulic Unit

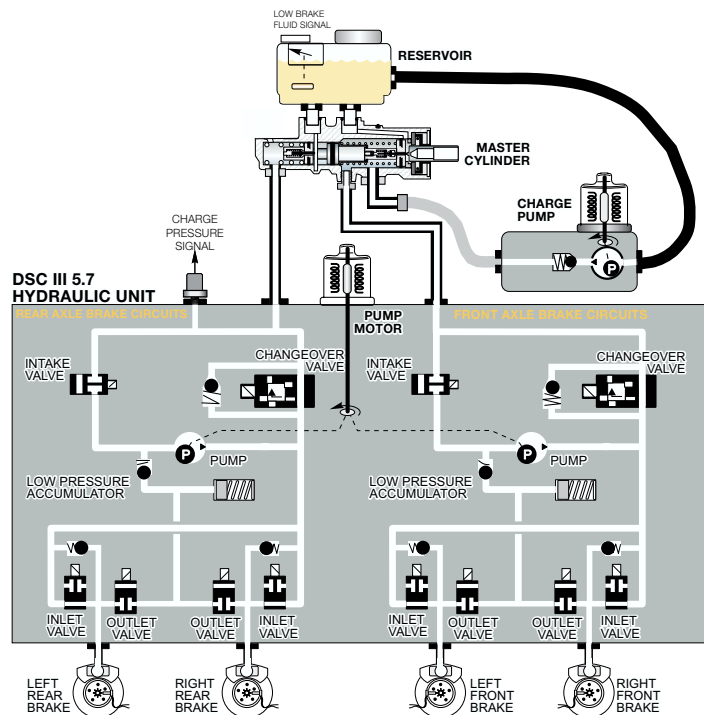

The hydraulic unit consist of an aluminum block containing 12 solenoid valves, 2 pressure accumulators and the return pump.

- 4 inlet solenoid valves (N/O)
- 2 changeover solenoid valves (N/O)
- 4 outlet solenoid valves (N/C)
- 2 intake solenoid valves (N/C)

The solenoid valving ensures that normal braking is possible in the event of a defective control unit.

**Note:** N/O= Normally Open, N/C=Normally Closed

## CAN Interface

The Bosch DSC III 5.7 is connected to the CAN bus for communication with the AGS, DME control module, Steering Angle Sensor and the Instrument Cluster.

Using the CAN bus, all of the connected modules can receive information or send commands.

Communication with the DSC III 5.7 includes:

- **DME** - The DME sends current engine torque. DSC commands the DME to reduce (ASC/DSC) or raise (MSR) engine torque.
- **AGS** - The DSC commands the AGS to suppress shifts during regulation.
- **LEW** - The DSC receives steering angle information.
- **KOMBI** - The DSC commands the instrument cluster to activate or deactivate the warning lamps.
- All four wheels speed signals are sent over the CAN bus for use by other modules.

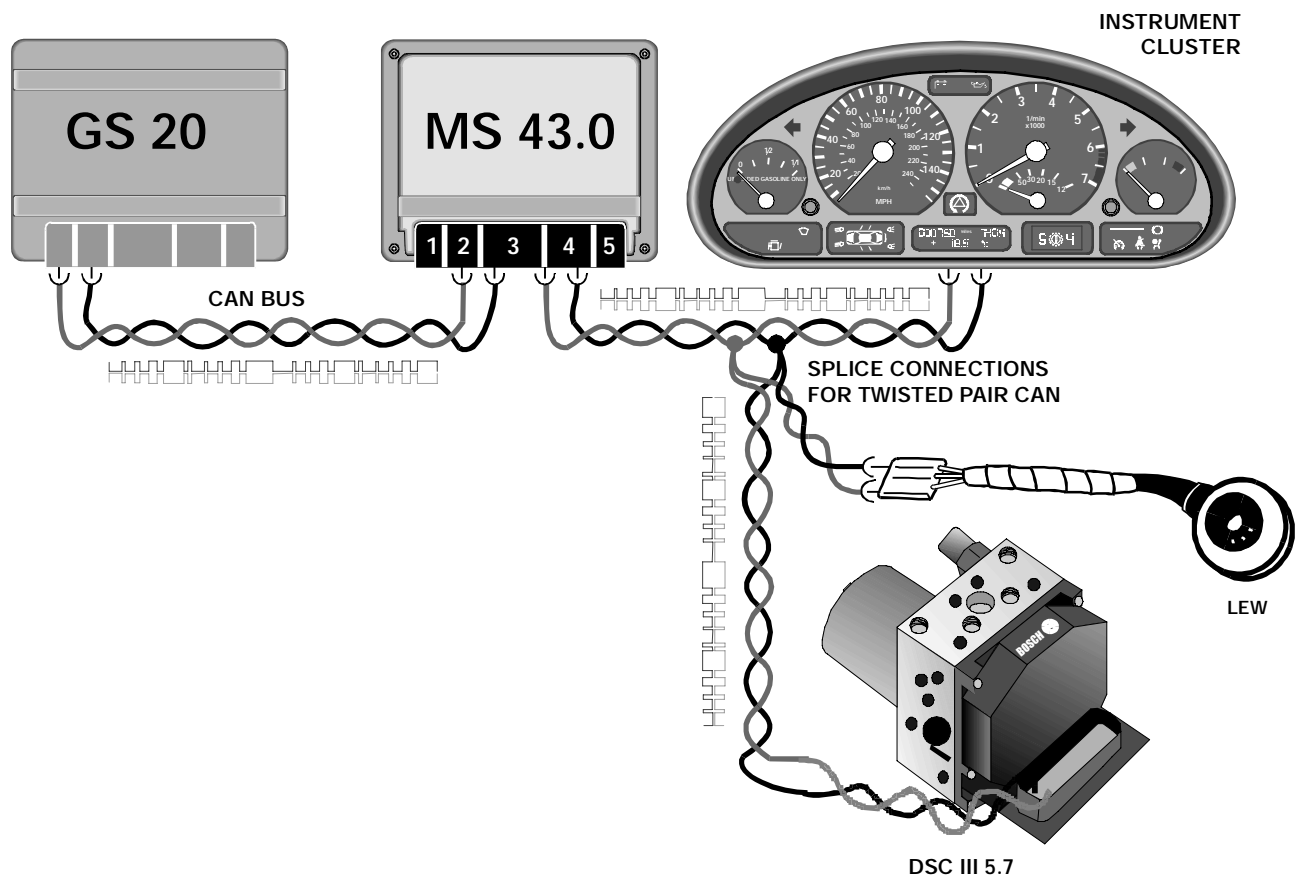

---

## Tandem Brake Master Cylinder

The DSC III 5.7 system uses a tandem brake master cylinder fitted with central valves as other DSC master cylinders. The central valves allow fluid to be drawn through the master cylinder during ASC and DSC regulation. The hydraulic circuit is split front/rear.

An orifice for pre-charge pressure is fitted into the brake front axle circuit and is connected to the pre-charge pump via a steel braided flexible line.

## Brake Fluid Expansion Tank with Integrated Level Switch

The brake fluid expansion tank has internal baffles that reduce foaming during return pump operation.

The expansion tank includes a pick-up tube for clutch master cylinder fluid supply and a second lower one for the charge pump supply.

The brake fluid level switch is incorporated into the tank. The switch is a reed contact switch. If the brake fluid is at a sufficient level, the switch is closed and switched to ground.



If the fluid level drops below a specified level, the reed contacts open and the DSC responds by switching off the ASC/DSC functions.

Normal braking and ABS operation is unaffected.

## Pre-Charge Pump

The pre-charge pump is located below the master cylinder in the left side of the engine compartment.

During ASC or DSC regulation with brake intervention, the DSC control unit activates the pre-charge pump. The pump delivers brake fluid at a pressure of 10 to 15 Bar to the front axle circuit of the master cylinder. The pressurized fluid also acts on the rear brake circuit of the master cylinder as well.

The Pre-charge pump ensures that an adequate amount of brake fluid is available at the hydraulic unit during brake regulation.

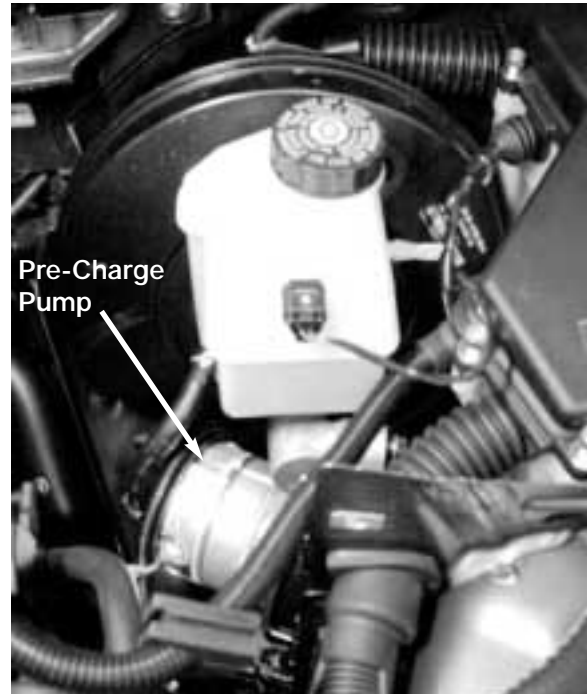

## Brake Pressure Sensor

The brake pressure sensor is mounted on the DSC hydraulic unit in the front axle circuit. The sensor is provided with a 5V reference voltage by the DSC control unit.

The sensor provides the control unit with an analog signal proportional to brake pressure. Voltage increases with increasing brake pressure.



## Plausibility with BLS

The signal input from the brake light switch is compared with the pressure sensor value.

The pressure sensor must not detect more than 5 bar when the BLS is not actuated.

Both signals are used to form a redundant BLS input which is monitored during all phases

---

## Brake Light Switch (BLS)

The brake switch is an input to the DSC to inform it that the brakes are being applied. If the signal is received during an ASC control, brake regulation is interrupted.

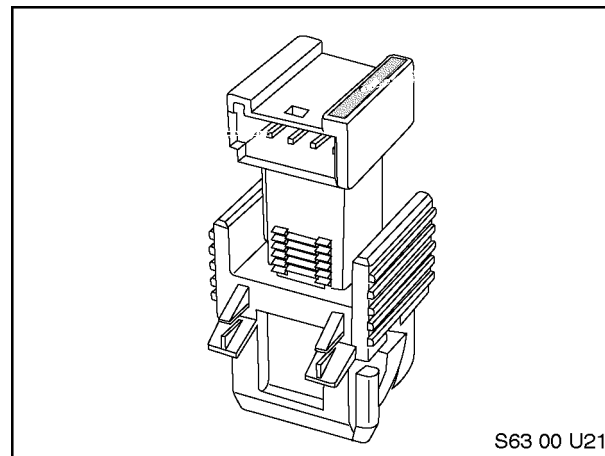

## Wheel Speed Sensors (Active)

The E46/16 uses Hall-effect wheel speed sensors similar to other models with Bosch DSC III 5.7. The advantages of the Hall sensors over the inductive sensors of the Teves MK 20EI are:

- Speed signal is available from 0.3km/h.
- Signal strength is not dependent on road speed.
- The signal supplied is a digital square wave.

The pulse wheel for the front axle circuit is integrated into the wheel bearing inner seal, identical to that of E38, E39, E53, E52 models.

The pulse wheel for the rear axle circuit is identical to 2wd E46 models. The pulse wheel is a plastic coated metal wheel attached to the rear stub axle outboard C.V. Both pulse wheels produce 48 pulses:1 wheel revolution.

The color of the sensor connector is blue, just as the Magneto-resistive sensors of the Teves MK 60 used on 2wd vehicles. The front sensors of the 2wd and 4wd versions of E46 are physically different and will not fit in the wheel hub.

The rear sensors can be confused with the Teves MK 60 sensors and will fit in the rear axle of the 4wd car however they are not compatible with the Bosch system.

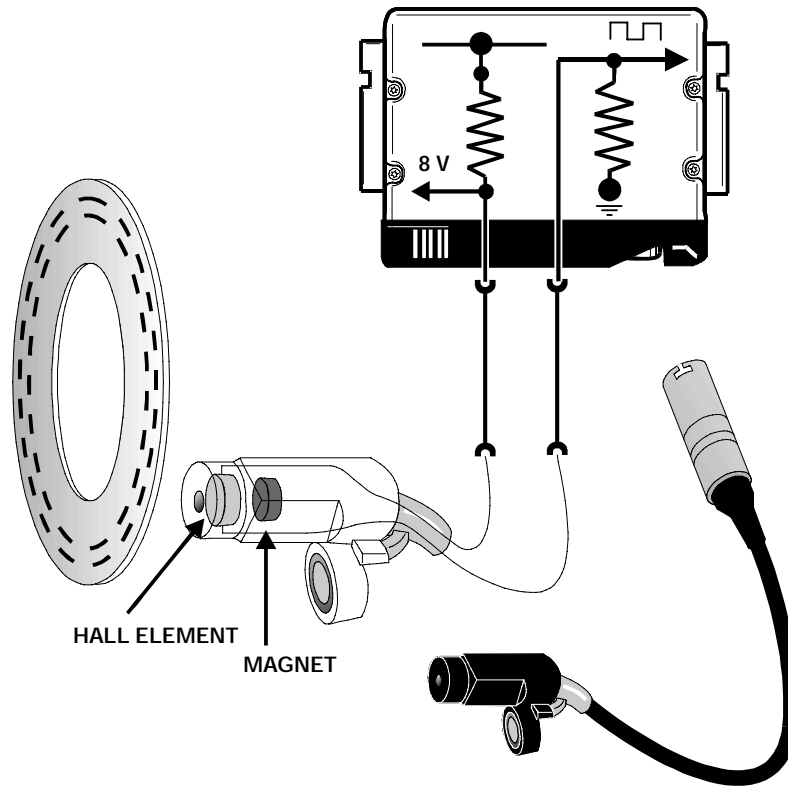

### Principle of operation of the active wheel speed sensor

The sensor housing contains the evaluation circuitry, a Hall-effect transmitter and a permanent magnet. The wheel speed sensor receives a stabilized 8V operating power supply from the control unit.

Both front and rear sensors are two-wire. One wire is for the power supply, the other provides a ground for the Hall element and also provides the input signal to the control module

If a tooth of the pulse wheel is opposite the sensor, the signal to the DSC III is high: approx. 1.9 to 3.9 V. When opposite of the gap, the signal to the DSC III is low at 0.35 to 1.3 V.

## Integrated Rotation Rate and Transverse Acceleration Sensor

The E46/16 uses the combined rotation rate /transverse acceleration sensor used in all Bosch DSC III 5.7 systems. The sensor is located under the drivers seat in front of the left seat rail and is attached to a plate with a rubber mounting to isolate it from vibrations.

For rotational speed, the sensor produces a reference signal of 2.5 volts and a voltage input signal from 0.7 to 4.3 volts. This signal represents the rotational movement (yaw) of the vehicle from the neutral straight ahead position.



The sensor also integrates the transverse acceleration signal (side-ways acceleration). The signal range is 0.5V increasing to 4.5V as side forces (g-force) increase. This signal is combined with the rotation signal to determine when to start DSC regulation.

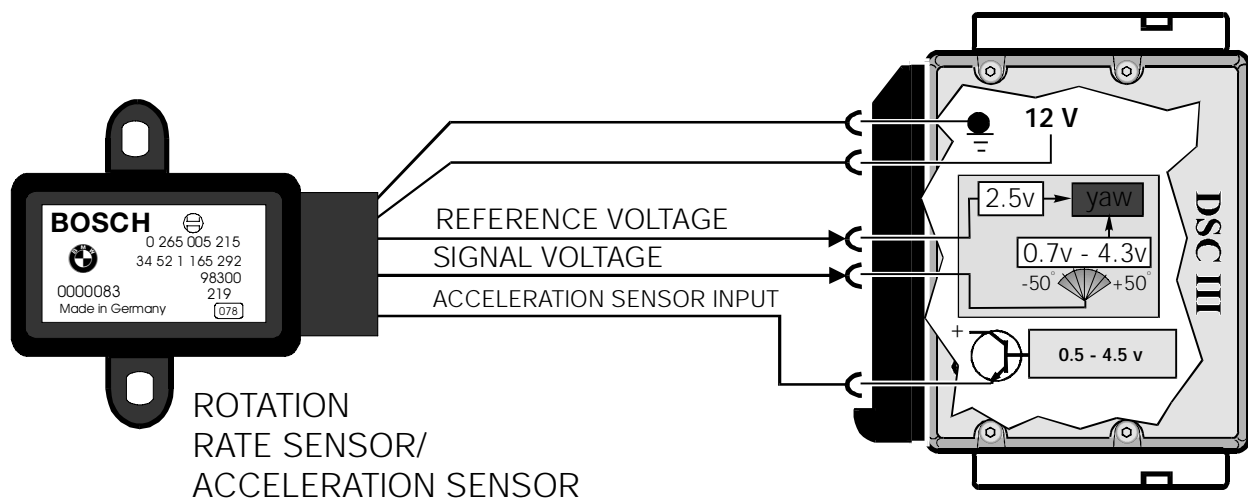

**Note:** Adjustment of sensors is conducted separately in Service Functions of the Diagnosis Program even though both sensors are contained in one housing.

## Steering Angle Sensor (LEW)

The Steering Angle Sensor is mounted towards the lower end of the steering column, above the flexible coupling. The LEW consists of a potentiometer and a built in microprocessor. The potentiometer has two pickups offset at 90° to one another. The raw potentiometer signal is processed and converted into a digital signal that is transmitted over the CAN bus to the DSC control unit.

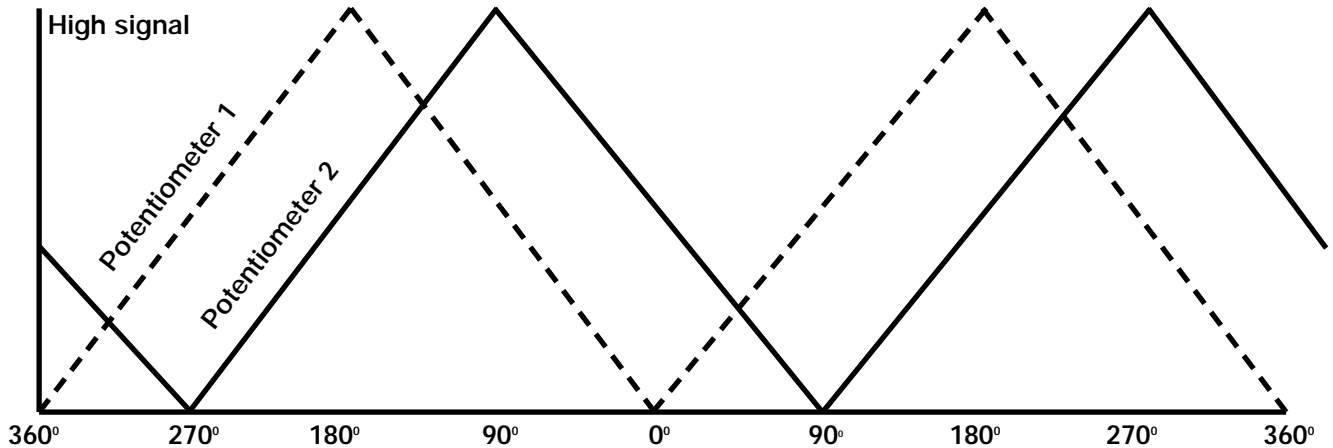

The sensor requires initialization in-order to create a zero point default. Once initialized, the LEW sends an ID number to the DSC control unit. The ID provides confirmation that the LEW is properly initialized.

The total steering wheel angle is determined by combining the CAN telegram signal, the stored zero point default and the actual number of turns to the wheel. In order to prevent the LEW from losing count, KL 30 is provided to the sensor and it continues to record even after the ignition has been switched off.

The DSC calculates the drivers desired rate of turn from the steering angle signal.

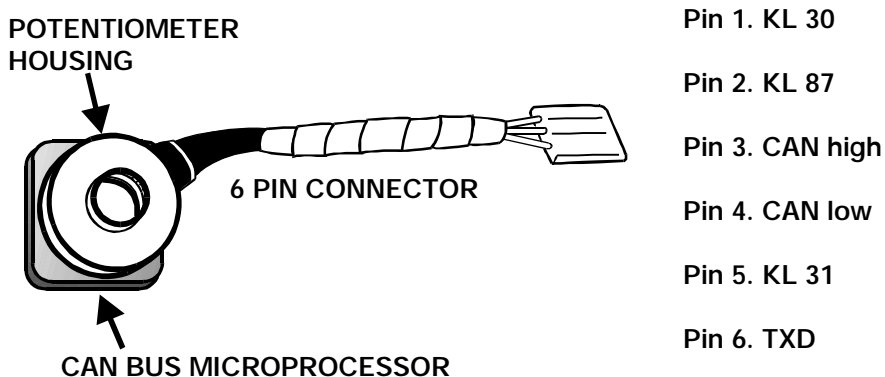

**Note: Refer to the Workshop Hints for instructions on coding and initializing the sensor.**

## DSC Button

The DSC button is located on the SZM however the SZM provides no processing, it is simply a housing for the button which is a hardwired input to the DSC control unit.

**The function of the button is different than for 2wd vehicles. Brake intervention remains active for the ADB function after pressing the button to turn off the DSC. Only ASC engine intervention and DSC yaw intervention are deactivated.**

The DSC warning lamp will be illuminated to remind the driver that these functions have been disabled. Pressing the button again returns the system to normal status.

## Instrument Cluster Warning Indicators



Three warning indicator lamps are arranged in the instrument cluster:

- DSC lamp: Indicates fault in DSC or system disabled by the switch.
- ABS lamp: Indicates a fault in the ABS system.
- ABL "BRAKE" lamp: This lamp is a general brake warning and illuminates two different colors.
  - Red indicates low brake fluid or hand brake engaged.
  - Yellow indicates DSC/ABS fault.

The DSC and yellow ABL lamps are controlled by the DSC control unit via the CAN bus. The ABS lamp is controlled directly by the DSC III 5.7 control unit via hard wire.

---

## Principle of Operation

The scope of control for the DSC III 5.7 is comprised of three systems:

- ABS
- ASC+T
- DSC

Based on signals coming from the various sensors the DSC III will determine which system is best suited to maintain control of the vehicle.

In addition to the three basic systems, there are several sub-functions which are activated during very specific circumstances. The sub-functions are:

- CBC
- EBV
- MSR
- ADB
- DBC
- MBC

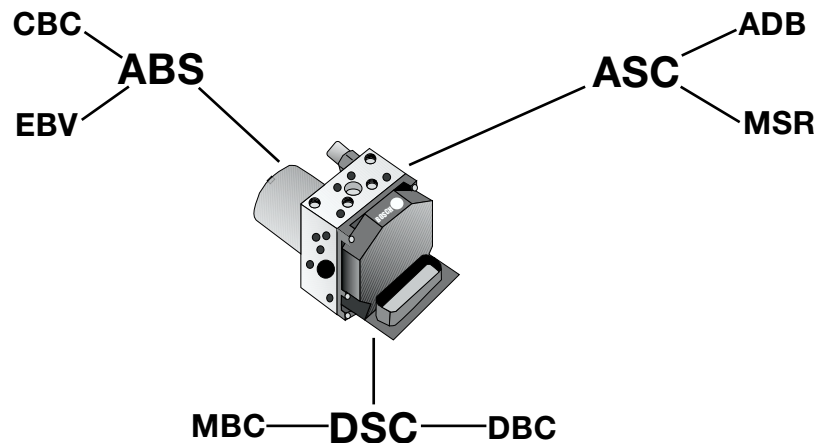

### System: Anti-Lock Braking System (ABS)

The ABS system can prevent wheel lock when braking by comparing the four active wheel speed sensors to the average vehicle speed. If a wheel is locking during braking or has dropped below a speed threshold programmed in the control unit ABS, braking will begin. ABS braking is possible when vehicle speeds are above 12 km/h (7mph).

The function of ABS for All-Wheel Drive use has an additional variation. During braking on loose surfaces the **wedge** effect is helpful. Gravel or dirt will build up in front of the tire when the wheel is locked, creating an increased braking effect. The system allows the locking of one or both front wheels up to approx. 20km/h (12mph). This "poor road surface logic" does not affect steerability. As soon as the control unit detects steering wheel change, the ABS system regulates normally again.

ABS regulation has three phases:

- Pressure Build
- Pressure Hold
- Pressure Release

Pressure Build already occurs during normal braking, so when ABS first intervenes it will start holding pressure by energizing the Inlet Valve. For example, if the right rear wheel is locking up, both Inlet Valves will be energized, regulating both wheels together. This logic is known as Select Low. Front wheels can be regulated individually as needed to prevent lockup.

Energizing the Inlet Valve closes the brake fluid passage to the calipers and traps the fluid at the current pressure, thus not allowing the brake pressure to rise any further.

If the wheel speed does not increase, the Pressure Release phase begins.

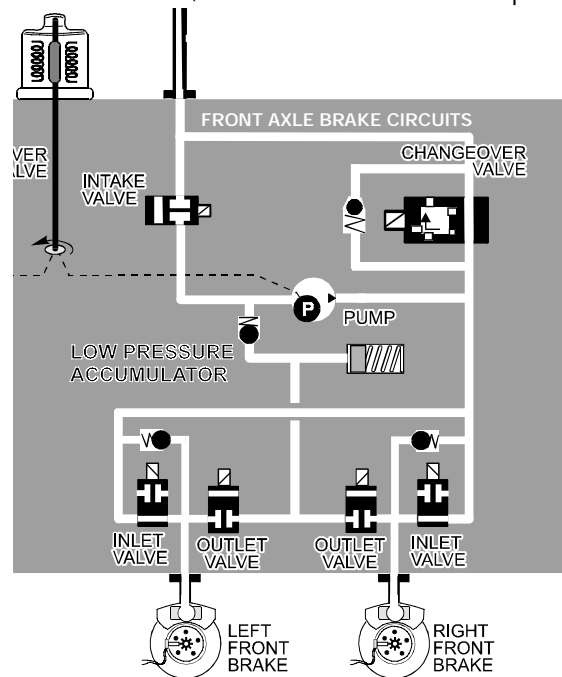

Pressure Release occurs when the control unit energizes the Outlet Valve while continuing to hold the Inlet Valve closed. The trapped brake fluid is released out of the calipers reducing braking pressure.

At the same time the pump is switched on which draws in the released brake fluid and pumps it back into the pressure build-up circuit restoring the volume of brake fluid again in front of the Inlet valve.

Depending on conditions the ABS system may cycle between these three phases from 3 to 12 times a second to prevent wheel lock.

---

## ABS Sub-functions

### Corner Brake Control (CBC)

CBC can occur if the vehicle is cornering and ABS regulation is not taking place.

If the control unit detects transverse acceleration in excess of 0.6g and the brakes are applied, CBC prevents a build up in brake pressure to the inside rear wheel. This prevents the vehicle from entering into an unstable situation that can lead to **Oversteer**.

The DSC III accomplishes this by closing the Inlet Valve, thus not allowing brake pressure to increase at the brake caliper.

The difference in braking force between the two rear wheels creates a yaw force that opposes the oversteer and allows the vehicle to handle **neutrally**.

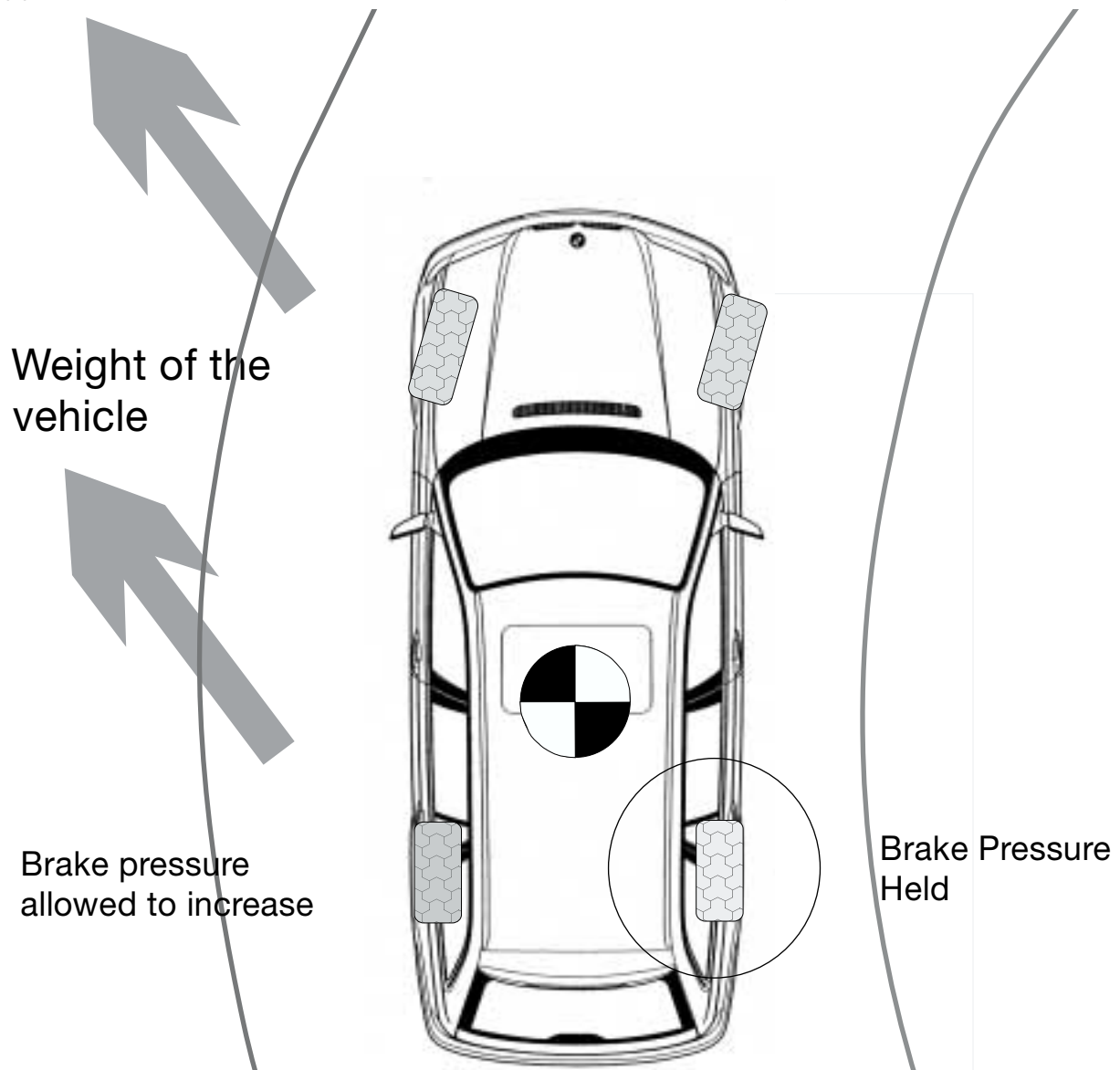

---

## Electronic Brake Force Distribution (EBV)

EBV will adjust brake pressure to the rear axle based on the rate of slow-down of the rear wheels, ensuring even brake force between the front and the rear of the vehicle.

The control unit monitors the wheel speed when the brakes are applied and compares the deceleration of the front and rear axle to determine required regulation.

If the vehicle is moderately to fully loaded the rear axle will take longer to slow down, rear wheel brakes can then be applied at a higher pressure .

If a vehicle was lightly loaded, a similar brake pressure would be too great and result in an unstable situation.

If EBV control intervention is required, the control unit cycles the inlet valve on the rear brake calipers to prevent further build-up.

Benefits of EBV are:

- Enhanced braking due to even distribution of brake force.
- Rear wheel brake size can be increased.
- Front and rear brakes wear at a similar rate.

---

## Automatic Stability Control (ASC+T)

ASC prevents unintentional wheel slip of the drive wheels in every situation.

The DSC III control unit determines if the vehicle is losing traction due to excessive longitudinal wheel slip based on input from the wheel speed sensors. An ASC regulating sequence is initiated if the wheel slip exceeds the control units stored allowable values.

The DSC III can control longitudinal wheel slip by two means:

- Automatic Stability Control **ASC. Engine Intervention**
- Automatic Differential Brake **ADB. Brake intervention**

### ASC Engine Intervention

Engine torque may be reduced by:

- Reducing the throttle opening angle
- Retarding the ignition
- Canceling individual cylinders by fuel injection cutout.

The DSC III control unit determines the amount of torque reduction that is necessary and sends the request for regulation to the DME via the CAN bus.

### ADB Brake Intervention

The ADB is an automatic differential lock that improves traction. The slipping wheel is braked by pressure built up in the hydraulic unit. The drive torque can be transferred to the wheel with the greater traction, which can transmit drive power to the road. This function acts much like a limited slip differential.

Brake intervention is applied to the individual wheel which is losing traction by regulating the brake calipers in three phases:

- Pressure Build
- Pressure Hold
- Pressure Release

---

When brake intervention is necessary, the axle not being regulated must be isolated from the Pressure Build sequence in the hydraulic unit. This is accomplished by closing both Inlet Solenoid Valves for that axle.

Here is an example of an ADB brake intervention at the left rear wheel:

- The Changeover Valve for the rear brake circuit, the right rear and both front Inlet Valves are energized and closed.
- The rear brake circuit Intake Valve is energized and opened.
- The Return/Pressure pump is activated and draws brake fluid through the open Intake Valve from the Master Cylinder (via the Central Valve) and delivers the pressurized fluid to the open Inlet Valve braking the left rear wheel.
- Pressure Hold and Pressure Release are done by cycling the Inlet and Outlet Valves similar to the ABS sequence described previously.

The drive torque can be distributed to the wheels with high friction coefficients (traction).

**Transversal differential-lock function.**

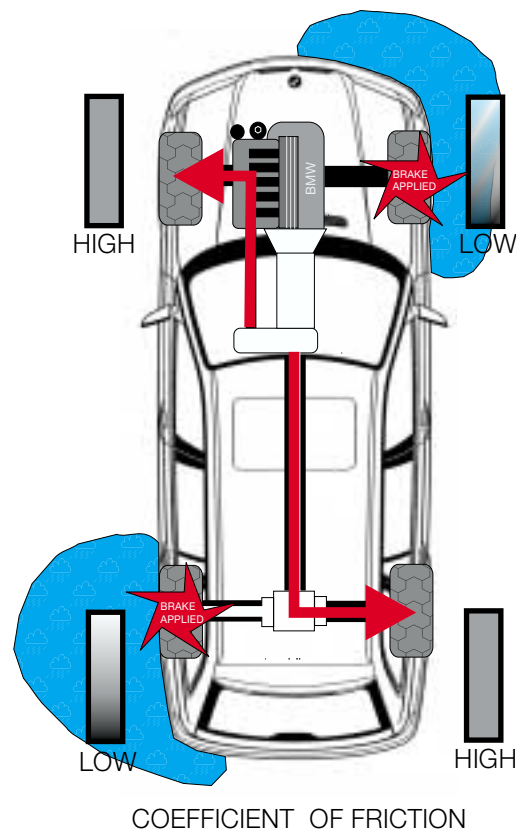

### Longitudinal differential-lock function

By performing brake intervention at the axle with a low friction coefficient, drive torque can be transmitted to the front wheels.

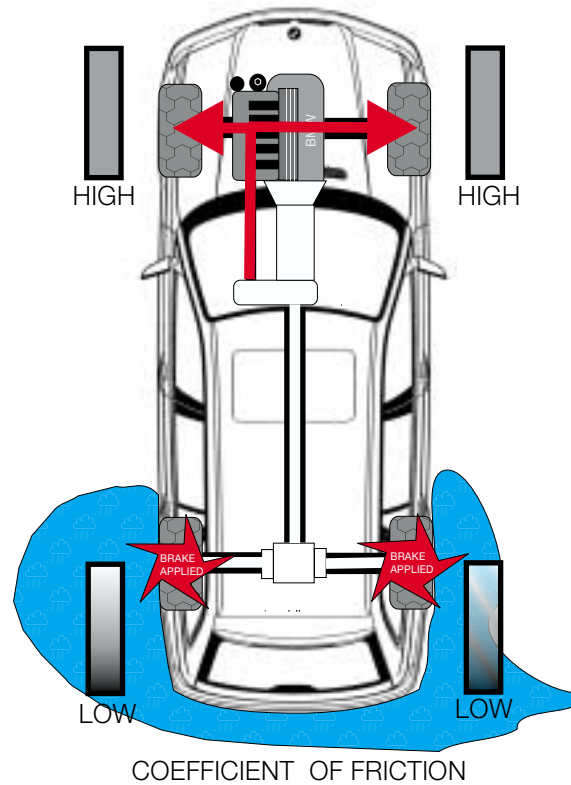

### Longitudinal and transversal differential-lock function

By performing brake intervention at the diagonally opposing wheels with a low friction coefficient, drive torque can be transmitted to the two wheels with more traction.

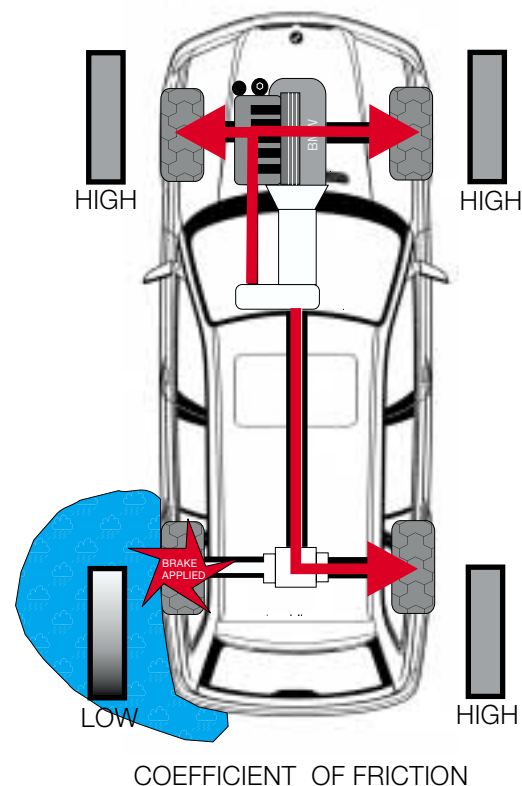

---

## ASC Sub-function

### Engine Drag Torque Reduction (MSR)

If the vehicle is driven in low gear when coasting down hill, or if there is a sudden shift to a lower gear, the wheels may be slowed down by the engine braking effect to rapidly. This could result in an unstable situation.

If the front wheels are turning faster than the rear wheels the DSC III control unit signals the DME via the CAN bus to **raise** the engine torque. DME cancels fuel cut-off and allows the engine speed to increase, this allows the drive wheels to accelerate to match the speed of the non-driven wheels.

MSR regulation is cancelled if the brake pedal or hand brake is applied.

### Dynamic Stability Control (DSC)

With the introduction of DSC systems, lateral dynamics were taken into account for the first time. The DSC III system will initiate a DSC regulation sequence if the control unit detects a difference between the drivers desired turning angle and the actual rotation angle of the vehicle. The control unit determines vehicle stability based on:

- Steering wheel angle
- Wheel speed
- Transverse acceleration forces
- Rotation angle and speed (yaw)

Once the control unit determines that the vehicle is in an unstable situation, it also identifies whether it is oversteering or understeering. This distinction is important because it determines which control strategy should be used to help stabilize the vehicle.

DSC regulation consist of :

- Engine intervention
- Engine and brake intervention (**any wheel**)
- Brake intervention

## Understeer

Understeer occurs when the driver wishes to turn a corner, but despite the front wheels being turned in the direction of the curve, the vehicle continues its forward track. This occurs when the front wheels no longer have sufficient lateral locating force (traction).

The DSC III can identify the situation and initiate a corrective action based on engine torque reduction followed by a controlled brake intervention sequence if needed.

Engine torque reduction is carried out by the DME from a request by the DSC via the CAN bus. The DME sends the torque reduction confirmation back to the DSC.

Brake intervention is carried out by the DSC III hydraulic unit if the driver is not actively braking. An example of a brake intervention at the inside rear wheel is as follows:

- All Inlet Valves are closed except for the right rear inlet.
- Intake Valve for rear circuit is opened.
- Both Changeover Valves are closed.
- Return pump operated.

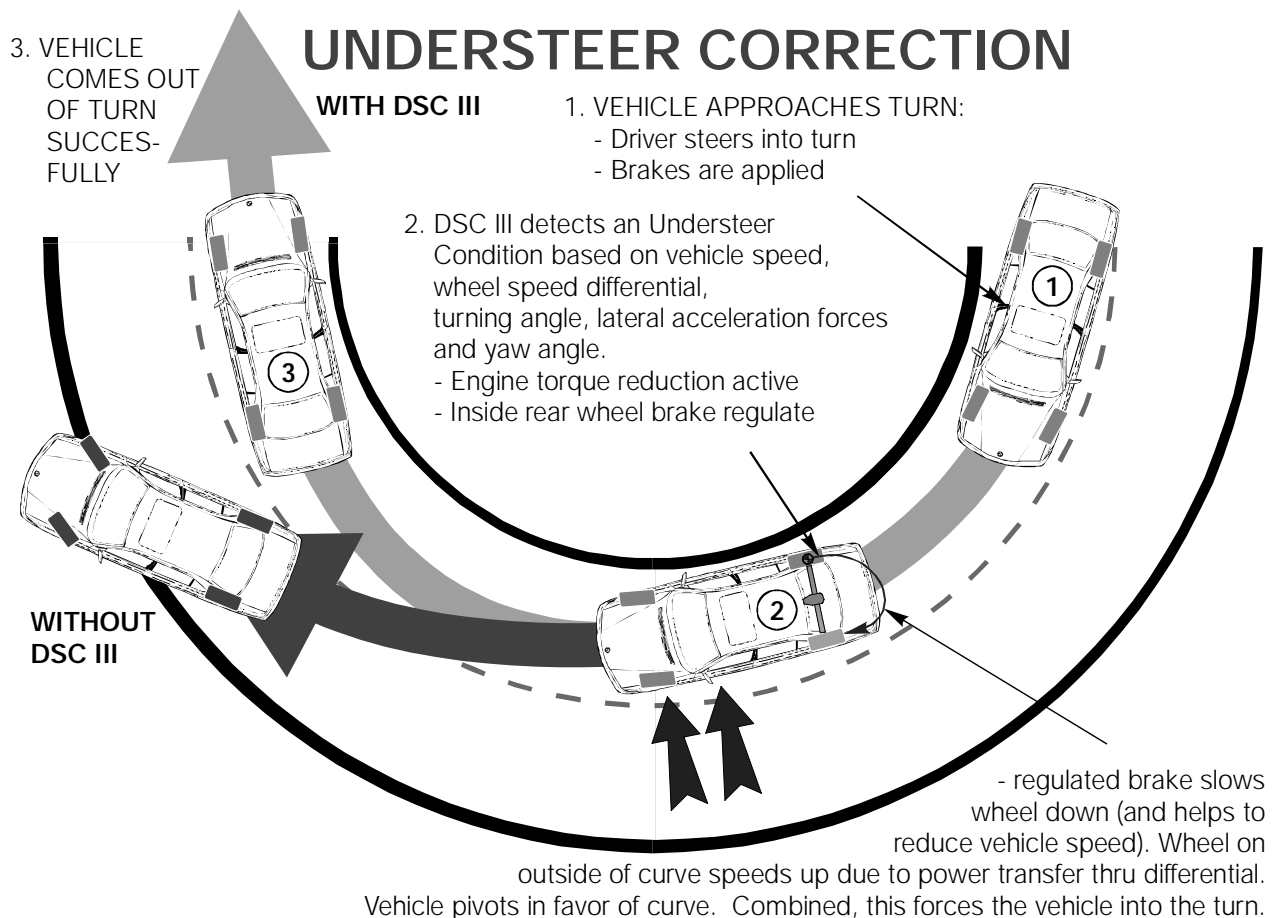

Just as an ASC regulation, DSC brake intervention carries out:

- Pressure Build
- Pressure Hold
- Pressure release

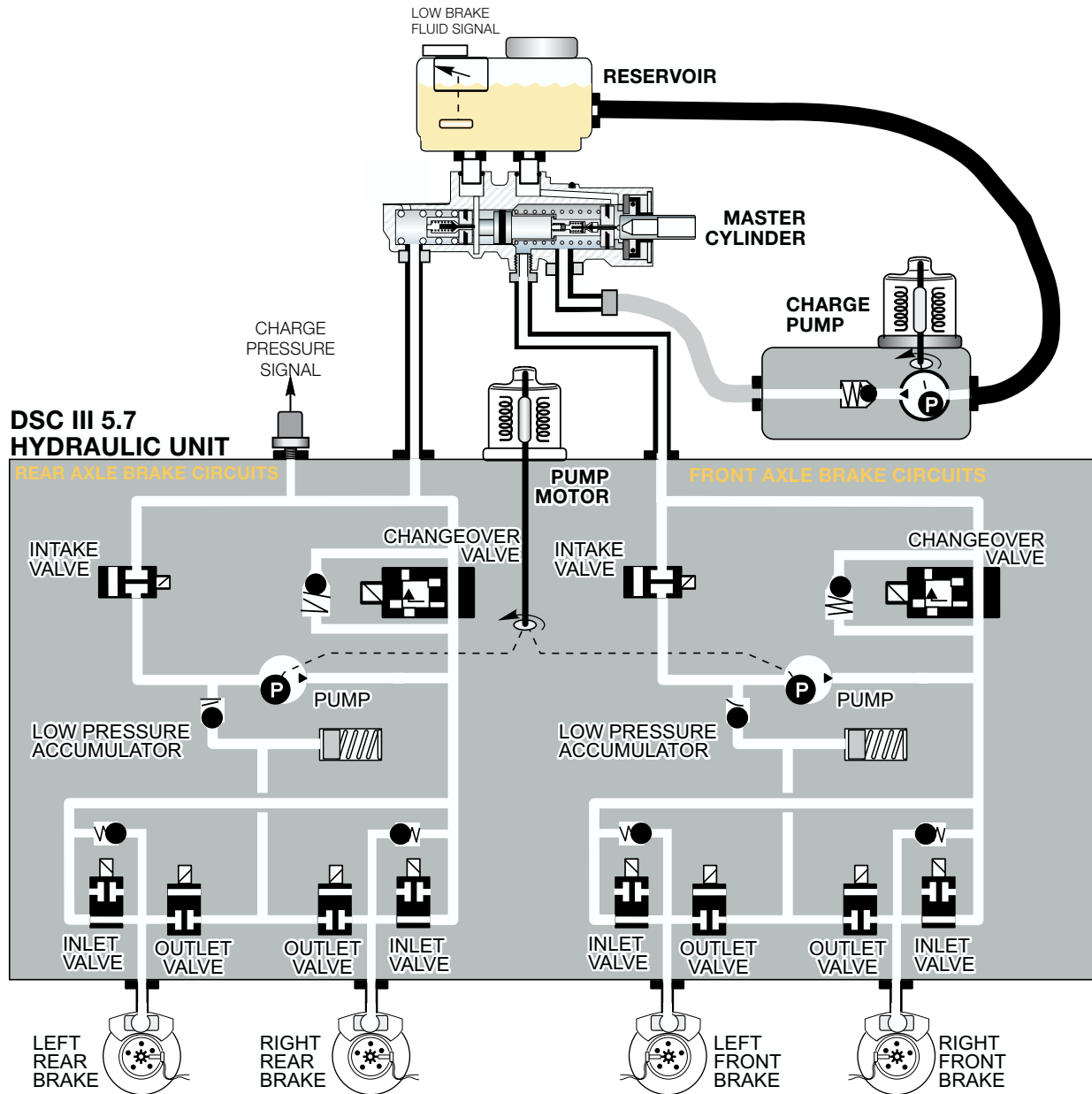

## Oversteer

Oversteer occurs when the driver wishes to turn a corner and the tail of the vehicle slides outward, leading the turn. This is caused by the rear tires losing traction and not being able to hold against the centrifugal force acting upon the vehicle.

The DSC III can identify the situation and initiate a corrective action based on engine torque reduction followed by a controlled brake intervention sequence if needed.

Engine torque reduction is carried out by the DME from a request by the DSC via the CAN bus. The DME sends the torque reduction confirmation back to the DSC.

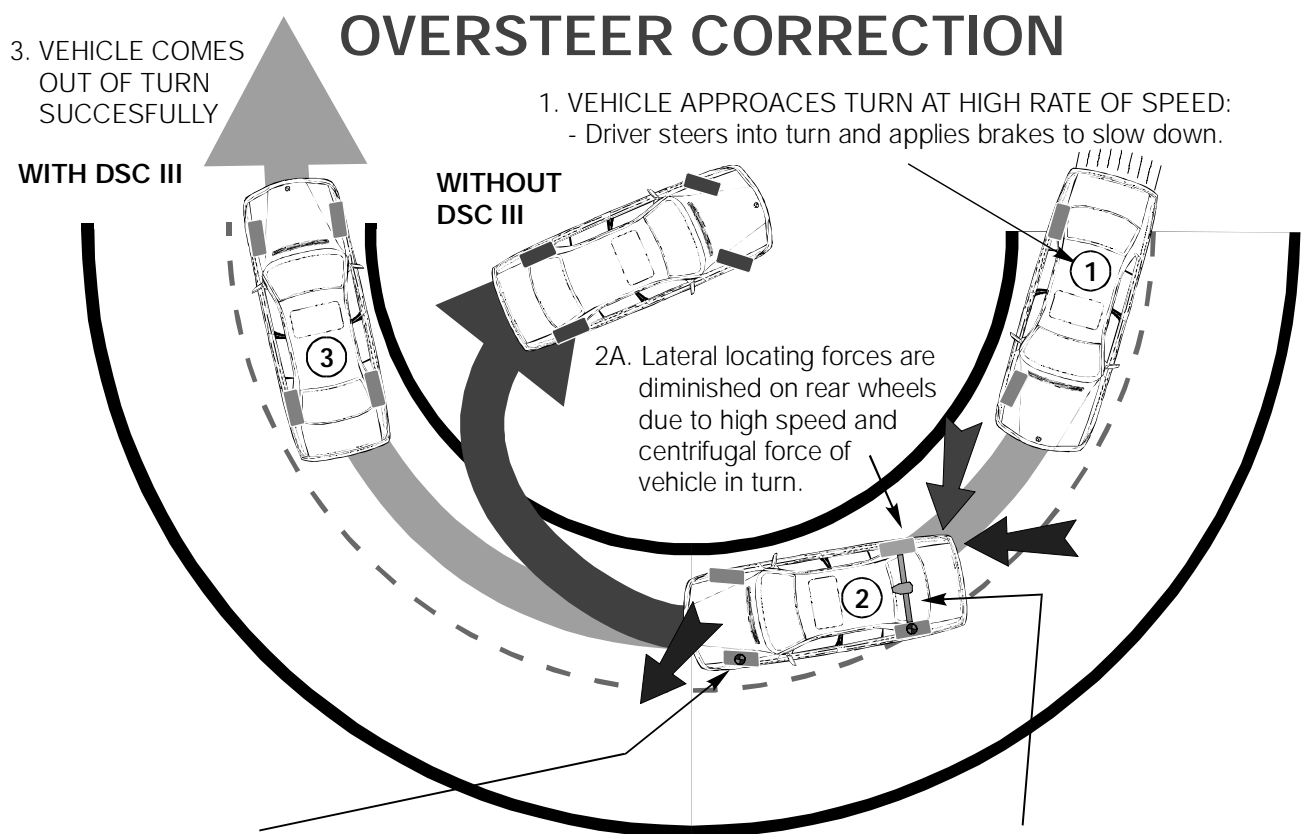

2D. The torque reduction and rear brake regulation should stabilize the vehicle at this point. If not the left front wheel has a high degree of lateral locating force and is momentarily regulated.

This action deliberately causes the wheel to shed a calculated degree of its locating force. This counteracts oversteer yaw at this wheel and also aids in slowing the vehicle down to correct it.

2B. Driver tries to compensate by oversteering which diminishes lateral locating force even further. Simultaneously, rear of car starts to slide out.

2C. DSC III determines an OVERSTEER condition. Engine torque is reduced via CAN Bus signalling. Outside rear wheel is momentarily regulated to counteract severe yaw angle (also helps to reduce drive torque further.)

---

## DSC Sub-functions

### Dynamic Brake System (DBS)

DBS is designed to assist the driver in emergency braking situations by automatically increasing pressure to the vehicles brake system. This allows the vehicle to stop in the shortest distance possible. DBS was first available in 1999 Bosch DSC III 5.7 systems.

The DBS system contains two functions: Dynamic Brake Control and Maximum Brake Control. DBS functions are programmed into the DSC III control unit and require no additional hardware over conventional DSC.

### Dynamic Brake Control (DBC)

The DBC function is designed to provide an increase in braking pressure up to the ABS threshold during rapid (emergency) braking situations. The DSC III control unit monitors the inputs from the brake light switch and the brake pressure sensor. The triggering criteria for activation of DBC is, how rapidly is the brake pressure increasing with an application of the brake pedal. The triggering conditions are:

- Brake light switch on.
- Brake pressure in the master cylinder above threshold.
- Brake pressure build-up speed above threshold.
- Vehicle road speed above 3mph (5km/h).
- Pressure sensor self test completed and sensor not faulted.
- Vehicle traveling forward.
- Not all of the wheels in ABS regulation range.

If the threshold for DBC triggering is achieved, the DSC III control unit will activate a pressure build-up intervention by activating the pre-charge and return pump. The pressure at all wheels is increased up to the ABS regulation point. This ensures that the maximum brake force is applied to the vehicle.

During DBC the rear axle is controlled with Select-Low logic and the front wheels are regulated individually. DBC will continue until:

- The driver releases the brake pedal.
- Brake pressure falls below threshold.
- Vehicle road speed below 3mph.

DBC will also be switched off if a fault occurs in with any of the necessary input sensors. A fault in DBC will illuminate the "BRAKE" (ABL) lamp yellow to warn the driver, depending on the failure the DSC lamp may be illuminated as well.

---

## Maximum Brake Control (MBC)

The MBC function is designed to support driver initiated braking by building up pressure in the rear brake circuit when the front wheels are already in ABS regulation.

The additional braking pressure is designed to bring the rear wheels up to the ABS regulation point shortening the stopping distance. The MBC function is triggered when the brakes are applied more slowly than the threshold needed for a DBC regulation. The triggering conditions are:

- Both front wheels in ABS regulation.
- Vehicle road speed above 3mph (5km/h).
- DBC and pressure sensor initialization test successful.
- Vehicle traveling forward.
- Rear wheels not in ABS regulation.

If the threshold for MBC triggering is achieved, the DSC III control unit will activate a pressure build-up intervention by activating the return pump. The pressure at the rear wheels is increased up to the ABS regulation point. This ensures that the maximum brake force is applied to the vehicle.

The MBC function will be switched off if:

- Front wheels drop out of ABS regulation.
- The driver releases the brake pedal.
- Brake pressure falls below threshold.
- Vehicle road speed below 3mph.

MBC will also be switched off if a fault occurs in with any of the necessary input sensors. A fault in MBC will illuminate the "BRAKE" (ABL) lamp yellow to warn the driver, depending on the failure the DSC lamp may be illuminated as well.

## Workshop Hints

Diagnosis of the DSC III 5.7 is carried out using the DISplus or MoDiC. The diagnosis program utilizes the symptom driven diagnostics taken from the E53.

The all-wheel drive models of the E46 series do not have their own model identification and all-wheel drive specific equipment (i.e. DSC III 5.7) is not detected automatically. All-wheel drive identification is performed by manually selecting it from a pop-up dialog box when a document or test module is called up which has a variation for all-wheel drive.

**Diagnosis:** Faults with the DSC III 5.7 system can be diagnosed using symptom driven test modules. To begin diagnosis:

- **Perform the Quick Test.**
- **Page right.**
- **Press the Function Selection Button.**
- **Select Complete Vehicle.**
- **Select Chassis.**
- **Select "Yes" for All-Wheel.**
- **Select Dynamic Stability Control.**
- **Press the Test Schedule Button.**

Diagnosis can occur using Fault Symptoms or Expert Mode troubleshooting.

**Service Functions:** Provides access to specialized functions used in post repair procedures. To enter:

- Select Service Functions while in Diagnosis Program.

The Contents are:

- **Test Code:** Used to print control unit fault information needed for component analysis.
- **Adjust Steering-Angle Sensor:** Used to adjust off-set for steering angle sensor when repairs or adjustments to steering have been made.
- **Adjust Transversal Acceleration Sensor/Adjust Rotation Rate Sensor:** Used to adjust offset for each sensor.
- **Bleeding,ABS/DSC Hydraulics /Precharging-pump circuit:** Used in purging air after repairs and for brake fluid flushes.
- **ABS/DSC Final Test:** Used to verify the proper brake pipe connections to the hydraulic unit and wheel speed sensor connections.

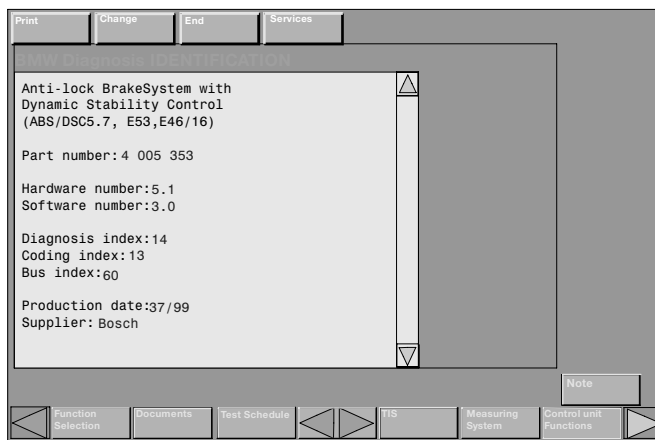

## Coding

Coding must be performed after replacement of the DSC III control module or the steering angle sensor. ZCS coding is found in the Coding and Programming selection from the start screen or when pressing the Change button. Follow on-screen instructions for initialization of components after completing the coding process.

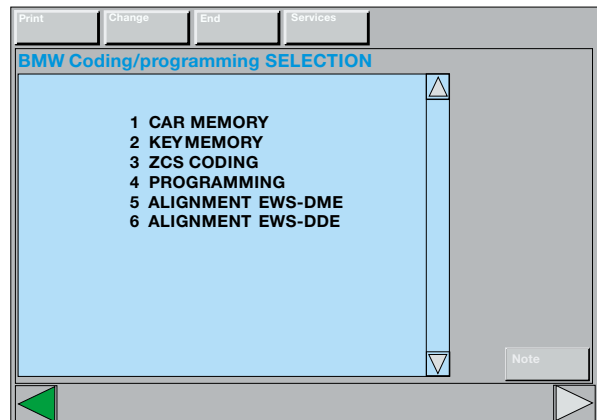

## Adjustment Functions

Adjustment (initialization) of certain components is required when:

- Replacing the DSC III Control Unit.
- Replacing/Re-coding the Steering Angle Sensor.
- Replacing Rotation/Lateral Acceleration Sensor.

## Steering Angle Sensor

The steering angle sensor requires an offset adjustment after the sensor has been replaced, coded or after repairs to the steering or suspension system. The offset adjustment informs the steering angle sensor processor of the straight ahead position of the front wheels.

The adjustment is performed by completing the Test Module found in Service Functions. Once the adjustment is complete, the sensor sends an identification number over the CAN bus to the DSC control unit. The ID provides confirmation that the steering angle sensor is coded and has successfully completed the adjustment procedure.

## Special Tools

Special Tools available for the Bosch DSC III 5.7 consist of:

42 Pin V-Cable 34 5 240

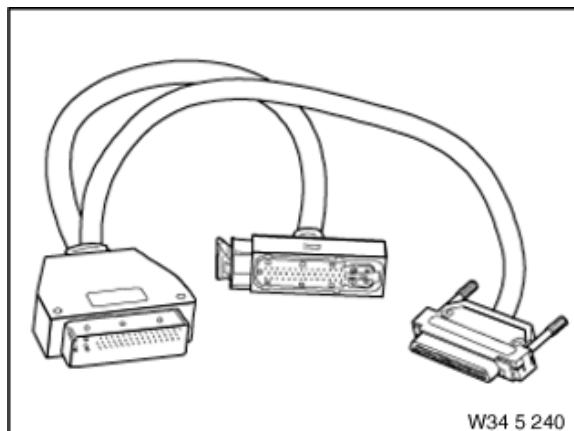

60 Pin Break-Out-Box

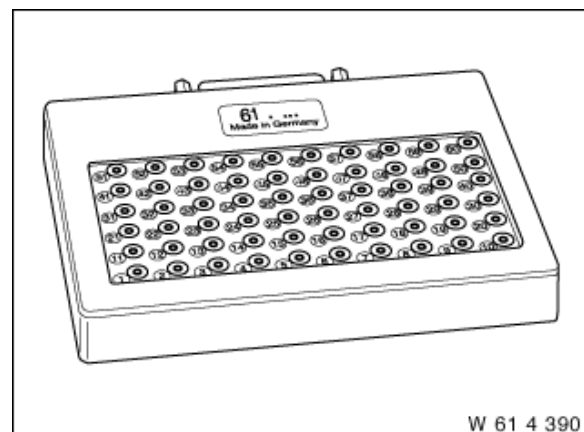

## Traction and Stability Control Systems Application Chart

	<b>E36</b>	<b>Z3/Coupe</b>	<b>E46</b>	<b>E39</b>	<b>E38</b>	<b>E53</b>	<b>E52</b>
<b>1998MY</b>	ASC+T	ASC+T MK IV G	N/A	9/97 ASC+T5 S: 528i  DSC III 5.3 S: 540i N/A 528i	9/97 DSC III 5.3 S: 740i/iL S: 750iL	N/A	N/A
<b>1999MY</b>	ASC+T MK IV G 328iC/318ti	ASC MK20 EI except M versions  ASC +T MK IV M/coupe/roadster	ASC MK20 EI	9/98 ASC+T5 S: 528i  DSC III 5.7 S: 540i O: 528i	3/98 DSC III 5.7 S: 740i/iL S: 750iL	N/A	N/A
<b>2000MY</b>	N/A	From 4/99 MK20 DSC III	6/99 MK20 DSC III	6/99 DSC III 5.7 Standard all models	3/99 DSC III 5.7 Standard all models	9/99 DSC III 5.7	1/00 DSC III 5.7
<b>2001MY</b>	N/A	From 9/00 MK60 DSC III  M-versions MK 20 DSC III	From 9/00 MK60 DSC III  M3 MK20 EI  E46/16 All wheel drive DSC III 5.7	DSC III 5.7	DSC III 5.7	DSC III 5.7	DSC III 5.7

**S = STANDARD EQUIPMENT**

**O = OPTIONAL EQUIPMENT**

---

## Review Questions

1. How does the MK20 EI ASC system communicate with DME to reduce engine power during an intervention? \_\_\_\_\_  
\_\_\_\_\_
2. Which component in the DSC III MK20 system is used to build-up pressure in the front axle circuit during DSC intervention? \_\_\_\_\_  
\_\_\_\_\_
3. What type of sensors are used in the MK20 ASC and DSC systems? \_\_\_\_\_  
\_\_\_\_\_
4. What is the difference in ABS control logic for the E46/16 in comparison to the 2wd models? \_\_\_\_\_  
\_\_\_\_\_  
\_\_\_\_\_
5. What service procedures are required when replacing a steering angle sensor?  
\_\_\_\_\_  
\_\_\_\_\_
5. What is the effect to the Bosch DSC III when the system is disabled by the DSC button? What about the button operation in the Teves MK60?  
\_\_\_\_\_  
\_\_\_\_\_  
\_\_\_\_\_
6. Describe the operation of the "Automatic Differential Lock" function.  
\_\_\_\_\_  
\_\_\_\_\_  
\_\_\_\_\_
7. Why is a pre-charge pump not required in the MK60 system? \_\_\_\_\_  
\_\_\_\_\_  
\_\_\_\_\_

---

## Review Questions

8. What is the purpose of the two sensors on the MK20 and MK60 DSC III master cylinder and what is their relationship with the BLS (Brake light switch)?

---

---

---

9. What is the difference of the signal produced by the magneto-resistive and a Hall-effect wheel sensor? \_\_\_\_\_

---

---

---

10. List the various sensors used to detect oversteer/understeer in the DSC III systems.

---

---

---

---

11. What is the purpose of the DBS sub-function? \_\_\_\_\_

---

---

---