Table of Contents

Subject	Page
Complete Vehicle	2
Objectives of The Module	2
Purpose of The System	3
System Components	4
E46 MS Specifications Table	5
Vehicle Dimensions	5
Body Specifications	6
Engine Specifications	7
Running Gear / Miscellaneous Specifications	8
E46 M3 Body	9
Floor Assembly / Luggage Compartment Floor	10
Side Frame / Wheel Arches / Side Panels	12
Hood / Front Bumper / Rear Bumper / Fuel Filler Cap	12
Underbody Panels	13
E46 M3 Interior/Vehicle Trim	14
E46 M3 Sports Seats	15
Seat Design	16
Seat Functions	17
Aero Outside Mirrors / M-Multifunctional Steering Wheel	18
Cockpit	19
Central Body Electronics	20
Review Questions	22

COMPLETE VEHICLE

Model: E46 M3

Production Date: 01/2001

Objectives of the Module

After completing this module, you will be able to:

- Identify the differences on the E46 M3 from other production vehicles.
- List the Bus Systems used on the E46 M3.
- Describe the Sports Seat operation.
- Describe the Driveline and Running Gear used in the E46 M3.

E46 M3 Complete Vehicle

Introduction

The E46 M3 is the third generation of the M3 replacing the E36 M3.

In comparison to its predecessor, the high engine performance and dynamic driving characteristics is expressed in its sport-oriented design.

The E46 M3 is a high performance automobile which assumes the leading position in its class.

The E46 M3 is a high performance coupe based on the new E46/2 body.



00410000.tiff

System Components

The vehicle is fitted with an in-line 6-cylinder 3246 ccm engine (S54B32) which is used worldwide. The 4-valve induction engine with high pressure VANOS outputs 333 bhp at 7900 rpm. The maximum engine speed is 8000 rpm. The engine develops its maximum torque of 355 Nm at 4900 rpm. The engine management system is the MS S54. The drive train is reinforced to satisfy the engine's increased horsepower and torque.

The running gear of the E46/2 production vehicle and that of the E36 M3 form the basis of the E46 M3 running gear. In addition to the running gear which was specifically adapted to the M3, the vehicle also features: special wheels, Teves MK 20 dynamic drive control system, a variable locking M-differential and high performance brakes.

The design of the E46 M3 makes it capable for everyday driving, economic operation, and high performance while meeting environmental requirements.



11410000.tiff

E46 M3 Technical Data

Vehicle Dimensions

The overall length of the E46 M3 measures 4 mm longer than the E46 coupe (license plate bracket).

Compared to the E46/2 production vehicle, the track width on the front and rear axle of the E46 M3 have been increased considerably (track width: front axle +37 mm, rear axle +47mm). The new wider side panels enhance the sports character of the E46 M3.

E46 M3 Side View

(vehicle heights: 1372 mm Unloaded, 1363 mm loaded position)

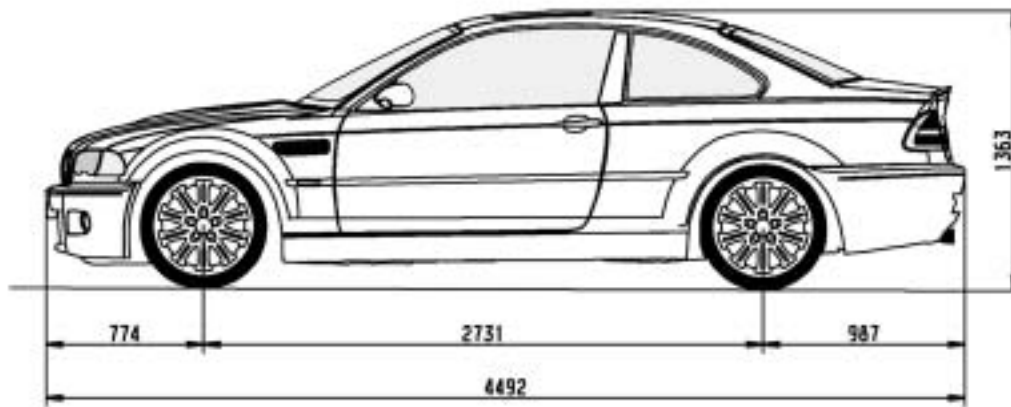

00410001.bmp

E46 Technical Data (Approach Angle)



00410002.bmp



00410003.bmp E46 M3 Front View

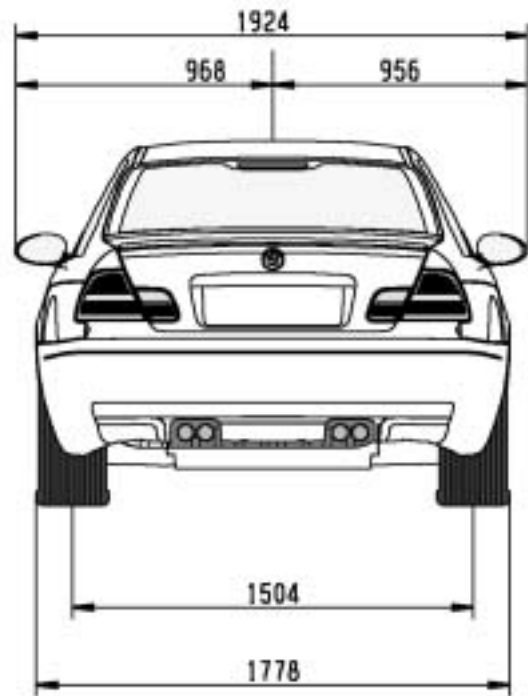

00410004.bmp E46 M3 Rear View

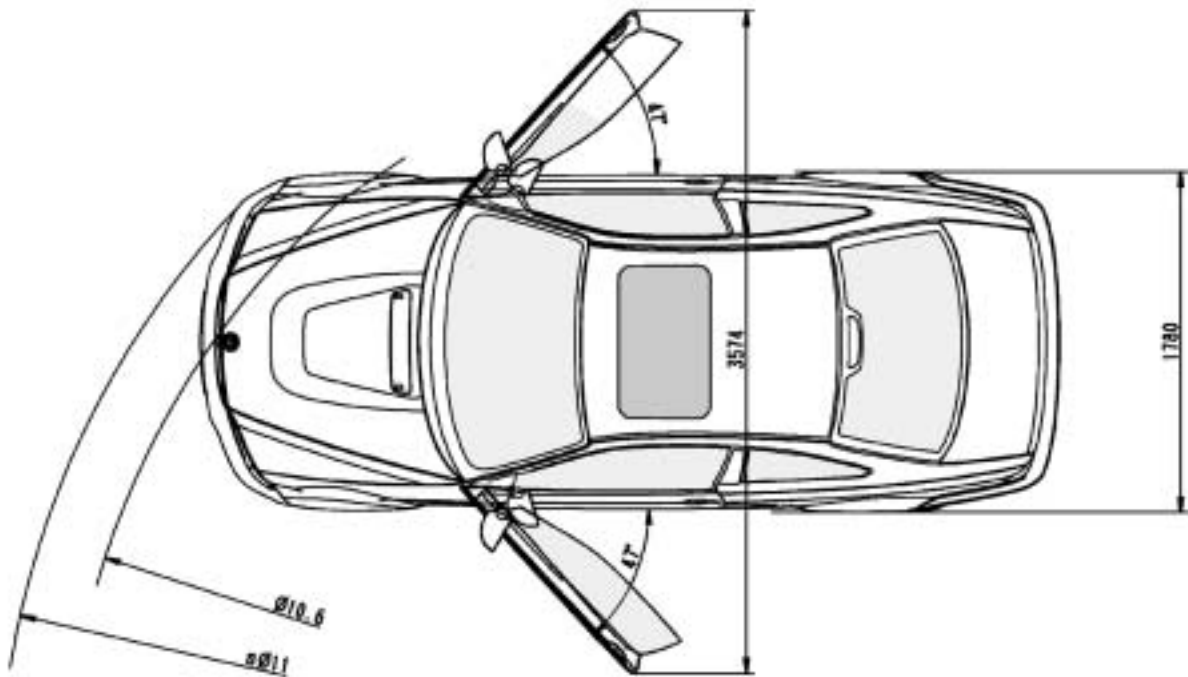

00410005.bmp

E46 M3 Top View

E46 M3 Specifications Table

	E46 M3	E36 M3
Body Version	Coupe	Coupe
Doors / Seating	2/5	2/5
Vehicle Length	4492 mm	4432 mm
Vehicle Width	1780 mm	1709 mm
Vehicle Height,Unladen	1372 mm	1336 mm
Wheelbase	2731 mm	2700 mm
Turning Radius	11.0m (36.1ft)	
Luggage Compartment Volume	410 L	291 L
Fuel Tank Capacity	63 L	62 L
Curb Weight, DIN	1495 kg	1441
Gross Vehicle Weight Rating	2000 kg	
Permissible Front Axle Load	970 kg	
Permissible Rear Axle Load	1140 kg	
Roof Load	75 kg	

	E46 M3	E36 M3
Engine Type	In-line, 6-cylinder, 4-valve	
	S54B32	S52B32
Engine Management	MS S54	MS 41.2
Engine Size	3246 ccm	3152 ccm
Stroke	91.0 mm	89.6 mm
Bore	87.0 mm	86.4 mm
Torque	355 Nm/4900 rpm	320 Nm/3800 rpm
Engine Output	333 bhp/7900 rpm	240 bhp/6000 rpm
Max. Engine Speed	8000 rpm	6800 rpm
Compression Ratio	11.5 : 1	10.5 : 1
Fuel Grade	Premium Unleaded	Premium Unleaded
Engine Oil Change Capacity With Oil Filter	5.5 L	6.5 L

E46 M3 Specifications Table

	E46 M3	E36 M3
Running Gear		
Gearbox Designation *	SG 6, Getrag D, S65420G	S5D ZF 310Z
Gear ratio, 1st gear	4.227	4.20
Gear ratio, 2nd gear	2.528	2.49
Gear ratio, 3rd gear	1.669	1.67
Gear ratio, 4th Gear	1.226	1.24
Gear ratio, 5th gear	1.00	1.00
Gear ratio, 6th gear	0.828	-
Gear ratio, reverse gear	3.746	4.13
Oil Capacity	1.9 L	1.2 L
Rear Axle Differential Gear Ratio	3.64	3.23
Oil Change Capacity	1.1 L	1.1 L
Type of Steering	Rack and Pinion Power Steering	

* **Note:** Refer to SMG II section for transmission specifications.

Miscellaneous	E46 M3
Aerodynamic Drag CD	0.33
Top Speed	155mph (governed)
Battery (V/Ah/A)	12/70/570 in luggage compartment
Alternator	70/120 Valeo
Washer Fluid (Reservoir fitted On Front Right Behind Front Apron)	5.3L

E46 M3 Body

Changes Compared to E46/2

The increase in engine output, torque, dynamic driving characteristics and sport design of the E46 M3 places more demand requirements on the individual components in the body. Visual, functional as well as technical features of the E46 M3 body have been modified in order to satisfy all these requirements. The individual changes contribute to increasing the E46 M3 body rigidity.

The visual differences of the E46 M3 as compared to the E46/2 in the body area include widening of the front and rear side panels, a modified aluminum hood as well as front and rear bumper covers.

The increased body rigidity is achieved by the use of additional gusset plates and weld points. Both functional and technical modifications have been made to the side frame structures, front and rear wheel arches, reinforcement in the C-pillar area as well as the luggage compartment floor.

The body of the E46 M3 corresponds to that of the E46/2 but with the following Changes:

1.	Floor Assembly / Luggage Compartment Floor
2.	Side Frame / Wheel Arches
3.	Front / Rear Side Panels
4.	Hood / Fuel Filler Flap
5.	Front Bumper
6.	Rear Bumper
7.	C-Pillar Reinforced
8.	Spring Strut Tower
9.	Rear Axle Mounts

Floor Assembly / Luggage Compartment Floor

The basic structure of the E46 M3 floor assembly corresponds to that of the E46/2 but with M3-specific modifications.

The luggage compartment floor has been modified in order to accommodate the larger rear silencer: The M-mobility system is mounted in a foam moulding in the luggage compartment floor.

The retaining fixtures for the large volume rear silencer are located on the outer ends of the under body.

E46 M3 foam moulding of M-mobility system in spare wheel well.

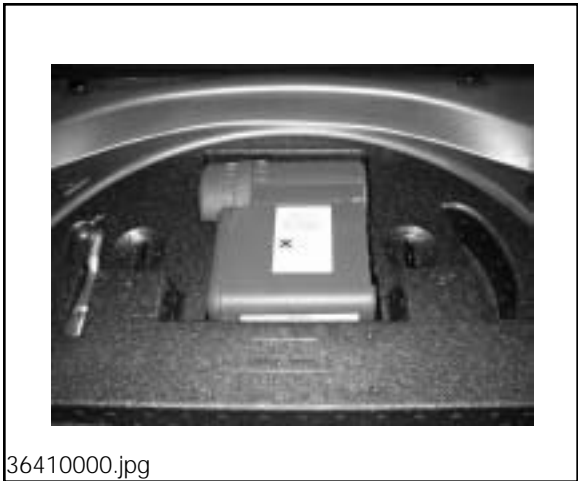

E46 M3 M-mobility Air Pump



Side Frame/Wheel Arches

Due to the larger tire sizes, the side frame structures of the E46 M3 are modified in the area of the wheel cutouts. The front and rear wheel arches have been modified for the larger tire sizes and track widths. The inner side section has also been modified as compared to the E46/2.

The C-pillar area features additional reinforcement.

The hole pattern of the front spring strut towers and rear shock absorber mounts is the same as on the standard parts.

Side Panels

The design of the front and rear side panels lends the E46 a sport appearance.

The front fenders have been formed corresponding to the tire sizes and track width. The fender side grill represents an M-GmbH development.

The rear quarter panels have also been formed corresponding to the tire sizes and track width.

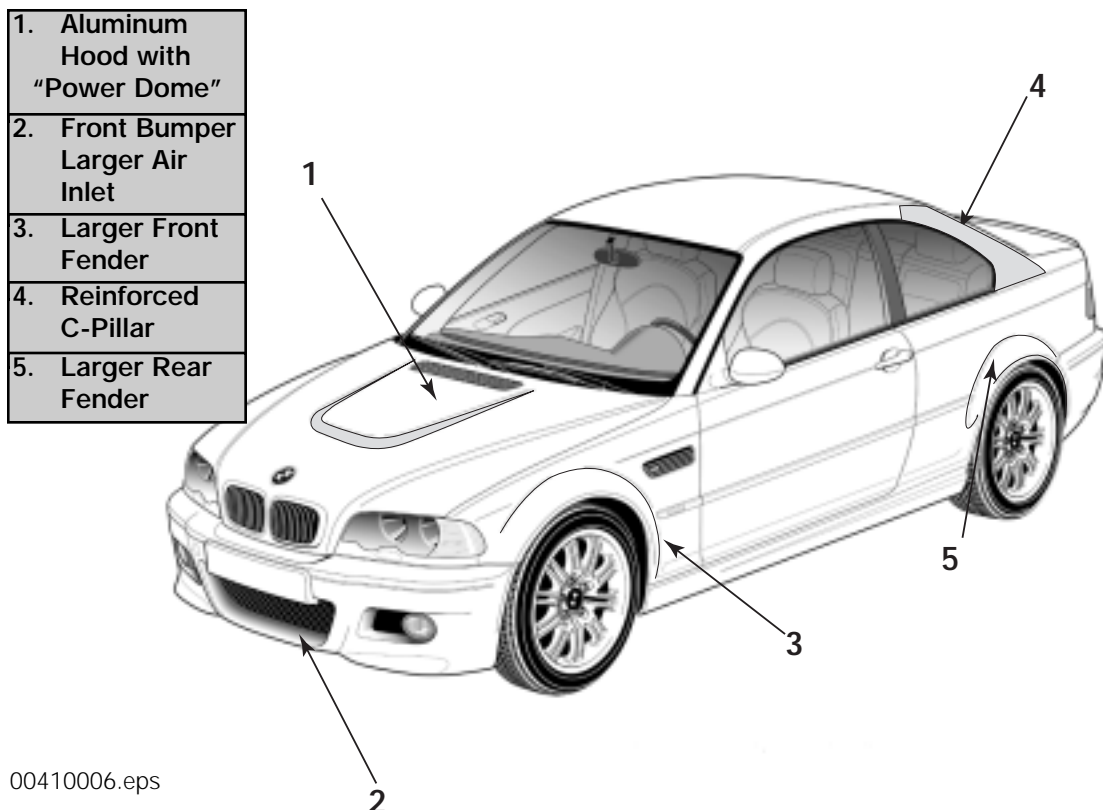

00410006.eps

Hood

The hood of the M3 is made of aluminum. The “power dome” is an elevated section in the center of the hood which accents the sports-oriented character of the vehicle. The hood consists of the outer skin panel, an inner panel and the front inner panel. A reinforcement plate is integrated at the rear left and right for mounting the hinges.

The gas struts for opening and closing the hood have been modified to the weight of the M3 hood. The hood latch is the same as that of the E46/2 production vehicle.

Front Bumper

The front bumper cladding is aerodynamically designed.

The air inlets for brake cooling next to the fog lights are closed off. The air inlet next to the left fog light is used for engine air intake.



41410000.tiff

Rear Bumper

The cladding for the rear bumper is also modified with painted PDC sensors. The PDC setting has been modified due to the changed positions of the PDC sensors in the rear bumper.



41410002.tiff

Fuel Filler Flap

The fuel filler flap is new and has been modified to the shape of the rear quarter panel.

Underbody Panels

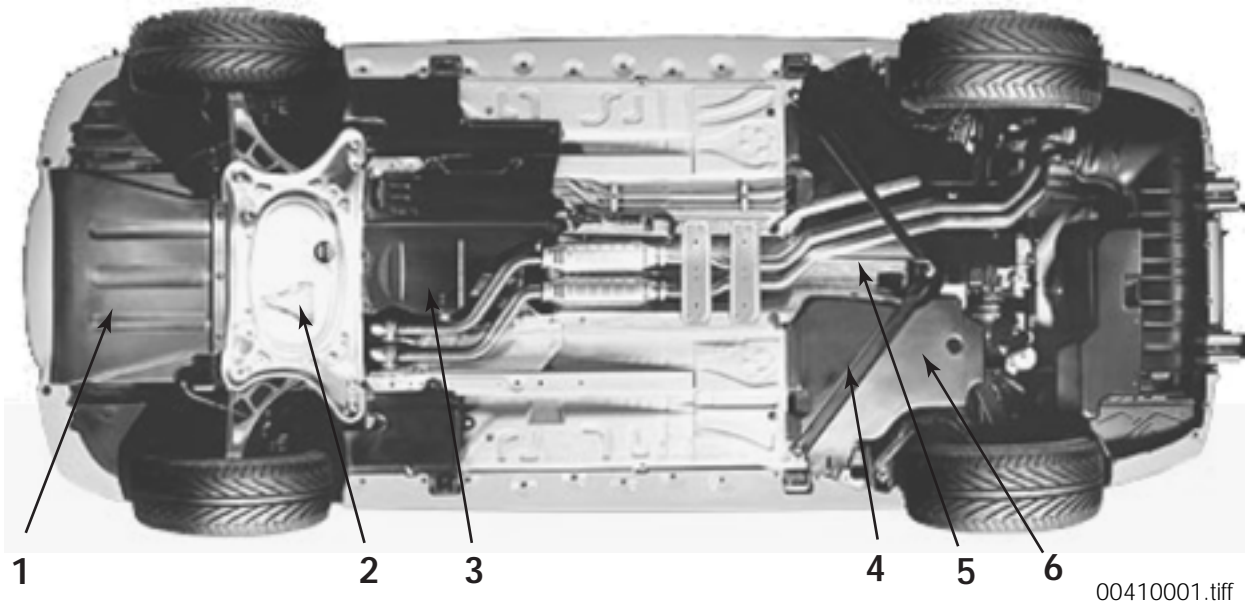

Index	Designation
1.	Engine Bottom Panel (provides negative lift at the front axle)
2.	Thrust Zone (reinforces the front axle area and provides specific cooling for the transmission)
3.	Transmission Panel (provides additional cooling for the transmission)
4.	V-Strut (connects the rear axle carrier to the body and reinforces the rear axle area)
5.	Propeller shaft panel with opening at the rear constant-velocity joints (heat guard and cooling of constant-velocity joint to rear axle differential output flange)
6.	Rear Filler panel

E46 M3 Interior/Vehicle Trim

The E46/2 serves as the basis for the Interior/Vehicle trim of the E46 M3.

The cockpit contains an M-Multifunction Sports Steering Wheel and specially designed seats.



The interior trim and upholstery of the E46 M3 corresponds to that of the E46/2 but with the following changes:

1.	M emblems, M trim fittings
2.	Inside and outside mirrors (M mirror)
3.	Interior trim panels and finishes
4.	Front seats (M Sport Seat)
5.	Rear Seats

E46 Trim and Accessories

1.	Multifunction Sports Steering Wheel (MFL II)	M-sport steering wheel with button pad for cruise control (right). Button pad for multimedia (left) functions same as E46 series
2.	Electric Seat Adjustment for Driver and Passenger (M-sport seat)	Electric seats optional
3.	Seat Heating	Driver and passenger same as E46
4.	Seat/mirror adjustment Including lumbar support	
5.	Windshield anti-glare strip	
6.	Heat-Insulated Windshield	Same as E46

E46 M3 Sports Seats

The M3 is equipped with sport seats as standard equipment. The seat is manufactured by Lear. The E46/2 sport seats serve as the basis for the M3 sport seats.

The sport seats are mechanical or electrical depending on the accessory package.

For the first time, a variable side support is offered as an option. Air cushions fitted in the left and right side upholstery can be inflated or deflated to adapt to the body shape of the driver.

In addition, a pneumatic lumbar support is fitted as in the E46/2.

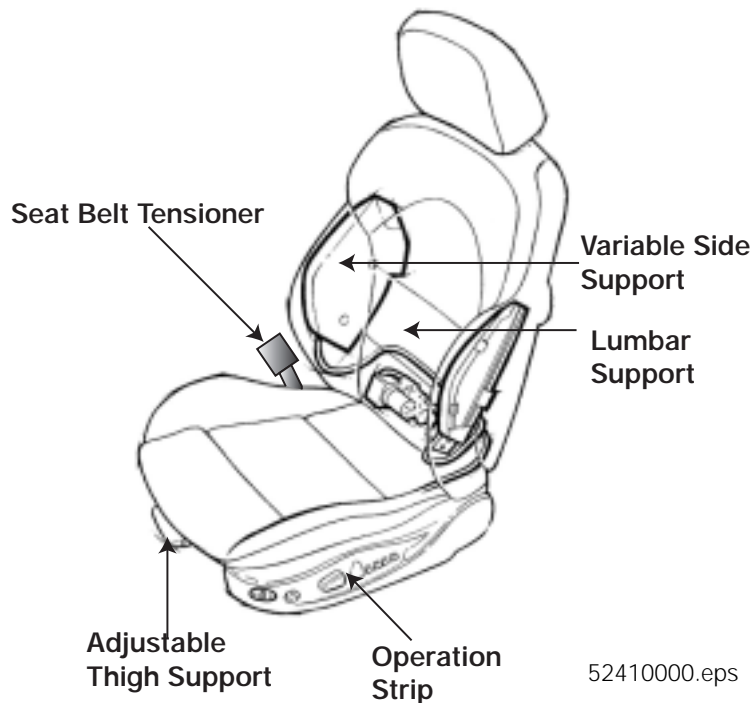

Seat Design

The air supply system of the M3 sport seat can be seen when the back panel is removed.

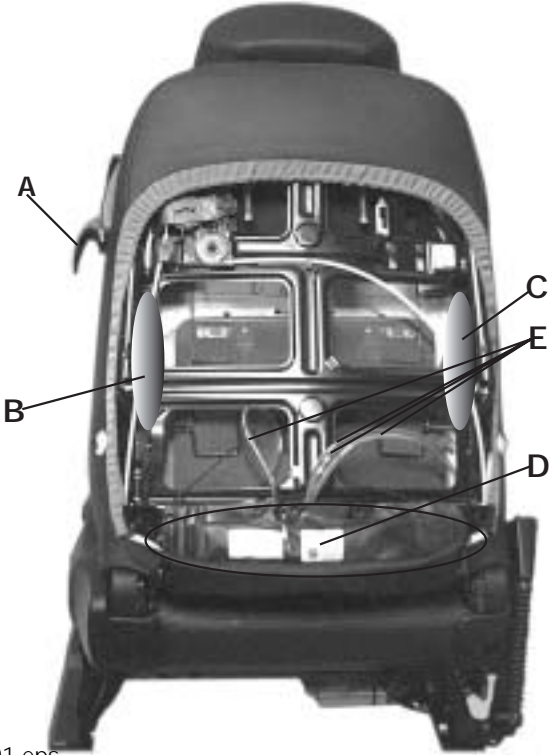

52410001.eps

Index	Description
A.	Adjustment mechanism for easy-entry function
B.	Position of air cushion for left side support
C.	Position of air cushion for right side support
D.	The pump unit for the lumbar support and side support upholstery is located in a plastic sleeve. The pump unit can be replaced.
E.	Air Supply Lines

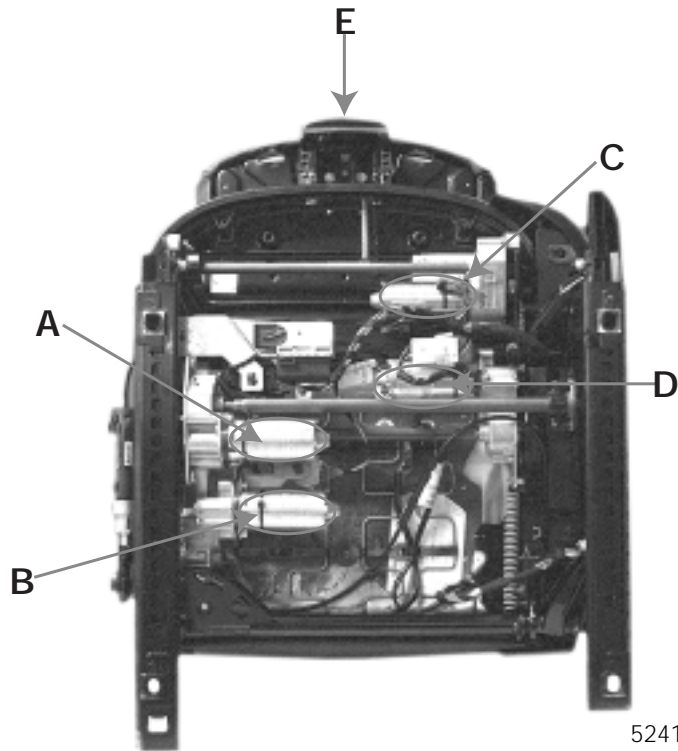

52410002.eps

A.	Motor for seat forward / backward adjustment
B.	Motor for seat backrest angle adjustment
C.	Motor for seat angle adjustment
D.	Motor for seat height adjustment
E.	Mechanical adjustment for thigh support

Seat Functions

A.	Adjustment switch for variable side support cushions
B.	Adjustment switch for lumbar support (for space reasons, the electronics of switch A are integrated in switch B). Switch A is M-specific.
C.	Seat adjustment switch (same as E46/2)
D.	Backrest adjustment (same as E46/2)
E.	Seat memory switch (driver's side only)

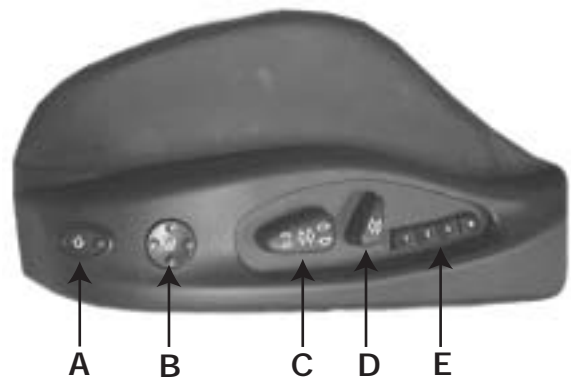

52410003.eps

E46 M3 General M Equipment

Aero Outside Mirror

The E46 M3 Aero mirrors can be “manually” folded up for additional clearance in tight spaces.



The driver can adjust the outside mirrors by the switch on the handle in the door trim panel. The mirror memory control unit is located in the front of the door behind the door panel.

The mirror adjustment and mirror heating functions correspond to those of the E46/2.

M-Multifunctional Sports Steering Wheel (MFL II)

The MFL in the E46 M3 is a BMW M development. The assembly and operation of the buttons for audio communication and cruise control function as in the E46/2.



Cockpit

Characteristic M styling elements in the E46 M3:

Sports steering wheel, instrument cluster, gearshift lever and center switching console.

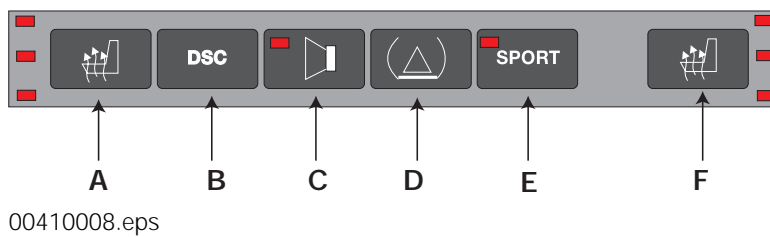

A.	Driver Seat Heater Switch
B.	Dynamic Stability Control
C.	Hi-Fi System Switch
D.	Tire Pressure Warning System
E.	Sport Switch (throttle opening characteristics)
F.	Passenger Seat Heater Switch

Central Body Electronics

The Body Electronic Systems of the E46 M3 are carried over from the E46 Coupe and Sedan models. The Driver Information System and Central Body Electronic System (ZKE V) continue to be used as the primary body electronic systems.

The M3 uses the "K" - Bus as the Primary communication link between body electronic control modules. The "D" - Bus is used as the diagnostic interface from the diagnostic equipment to the instrument cluster. The "CAN" Bus is used as the communication link between all power train systems. Finally, the "M" - Bus is used for IHKA operation of the flap control stepper motors.

E46 M3 Bus Systems

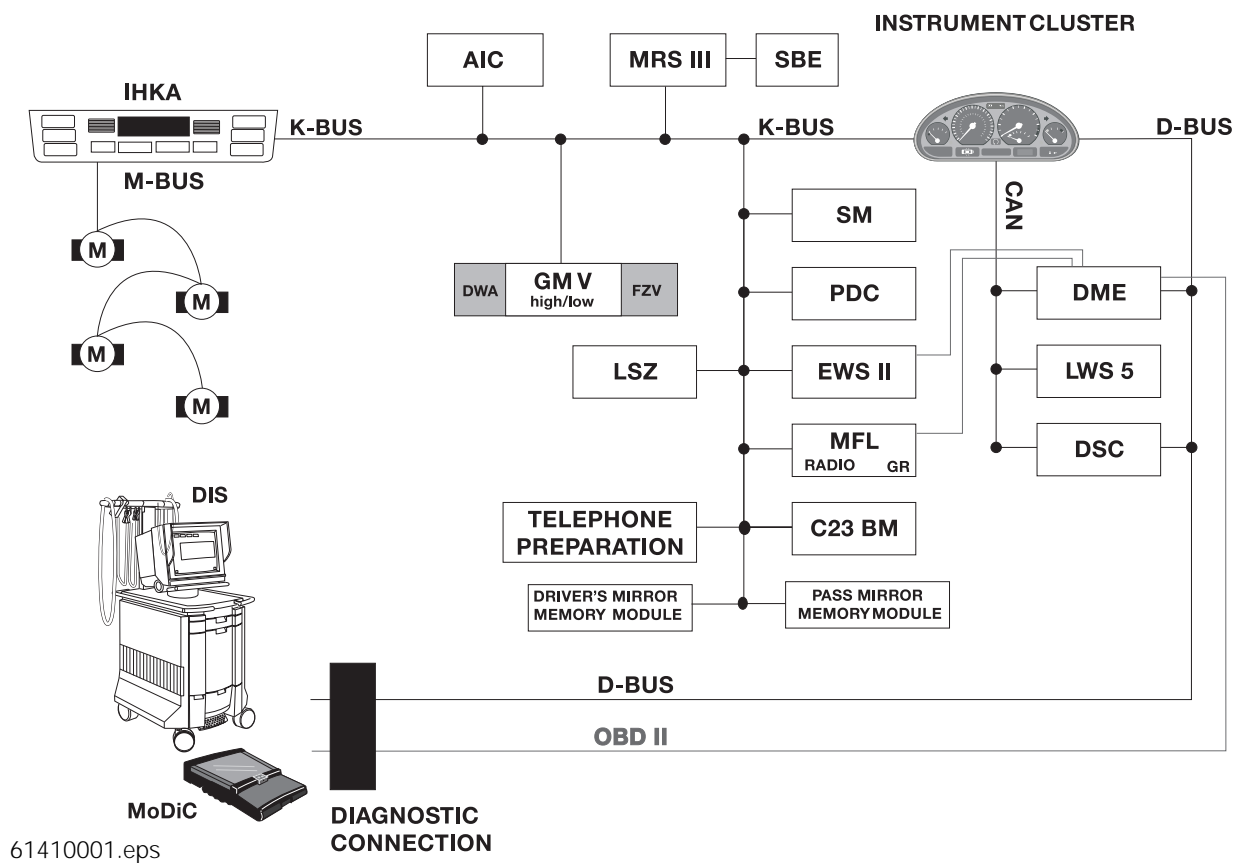

Instrument Cluster

The instrument cluster in the E46 M3 is similar to the cluster used in the coupes and it is the main source for information display. Information about the status of different operating systems in the vehicle is displayed through the gauges, LCD display, warning LEDs and Gong. Switches are also integrated in the instrument cluster to reset the trip mileage, perform BC functions and to change over some units of measurement e.g. degrees F to degrees C.

Additional to the E46 M3 Cluster is the use of an engine oil temperature gauge which replaces the fuel economy gauge below the tachometer.

The tachometer incorporates the cold engine warning LEDs that were introduced with the E39 M5. Starting at 4000 RPM, orange LEDs are illuminated with a cold engine start up. The LEDs will go out, in 500 RPM increments, as the engine warms up. The MS S54 engine control system monitors the engine oil temperature and signals the instrument cluster over the CAN line for operation of the oil temperature gauge and illumination of the LEDs.

Central Body Electronics (ZKE)

The following functions **are directly** controlled by the General Module (GM V):

- Windshield wiping/washing with optional Rain Sensor Interface
- Central locking with power trunk release
- FZV Keyless Entry
- Power window control
- Car Memory/Key Memory Capabilities
- Interior lighting
- DWA alarm system (optional)
- Consumer cut-off/sleep mode

The following functions are included as body electrical systems but are **not directly** controlled by the GM V:

- Rain Sensor
- Sunroof operation (Sunroof Control module on K Bus).
- Driver's seat electrical adjustment with memory (Seat Memory control module on K Bus)
- Passenger seat electrical adjustment (no control module - switch controlled)
- Mirror Memory - adjustment/heating (also includes windshield washer jet heating switch controlled)

Review Questions

1. What is the engine designation for the E46 M3? _____

2. What body components have changed for the E46 M3 as compared to the E46/2?

_____	_____
_____	_____
_____	_____
_____	_____

3. What function does the "Sport Switch" have? _____

4. List the Bus systems used on the E46 M3.

5. What new feature can be found in the E46 M3 Sports Seat? _____
